

Functional · SR Series White 5000K

lumher

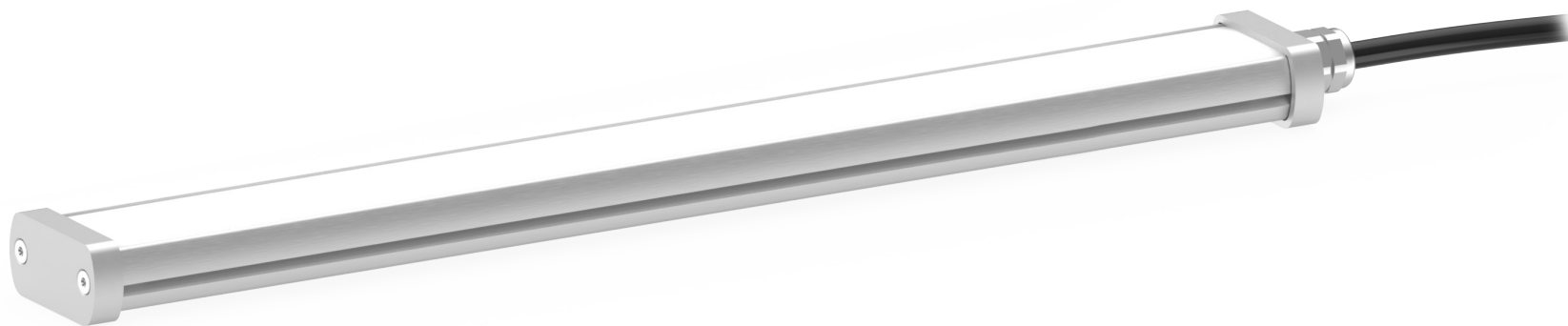

24 V
DC

155
lm/W

NOT
CASCADABLE

75 mm
INCREMENTAL

FUNCTIONAL

CABLE
M8A

POWER 1x
ECO 0.5x

IP40
IP65

PWM
DIMABLE

CLASS III

36
MONTHS

EU
MADE IN SPAIN

Technical specifications

Power supply voltage	24 Vdc \pm 5%	
Luminous efficiency	155 lm/W	
PWM regulation (Max 25 KHz)	min. 0%	max. 100%
Wavelength	Daylight white	5000K
Angle of aperture	Semidiffuse	60°
	Ultradiffuse	110°
Max. number of cascadable modules	This luminaire is not cascadable	
Electrical protections	Transient overvoltages	YES
	Polarity reversal	YES
	Current sablizer	YES
Colour Rendering Index (CRI)	\geq 80	
IP Rating	IP40 or IP65	
Protection type	Class III	
Operating temperature	POWER version	-10 a +40 °C
	ECO version	-10 a +50° C
Body material	Anodized aluminum	
Side cover material	Anodized aluminum	
Diffuser material	Polycarbonate	
Connection types	2m cable, M8 connector with cable	
Standards	RoHs, CE	

Connection

Input M8A - Cable	Power	Eco	Dual
Pin 1 - Brown	+24 Vdc	+24 Vdc	+24 Vdc
Pin 2 - White	Not connected	Not connected	24 Vdc = Power 0 Vdc = Eco
Pin 3 - Blue	0 Vdc	0 Vdc	0 Vdc
Pin 4 - Black	Not connected	Not connected	Not connected

M8A Male

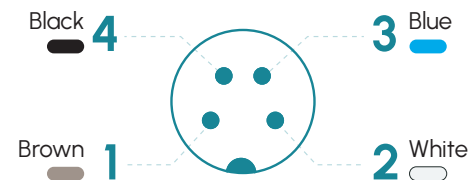

Anchors

S00G2

SR · 5000K



lumher

Dimensions

M8A axial version

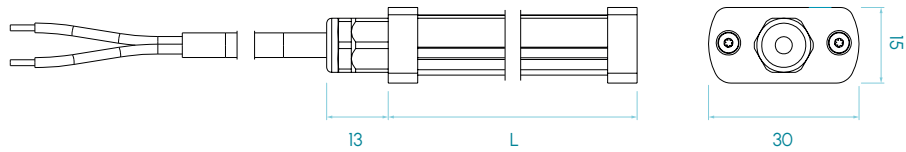

M8A radial version

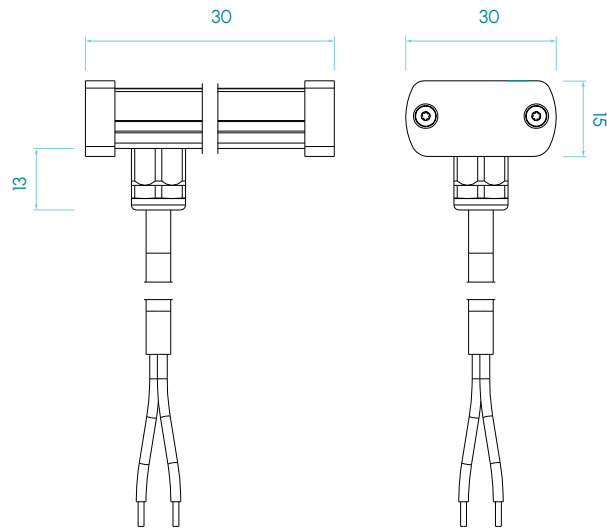

Dimensions in mm

SR · 5000K

Selection guide

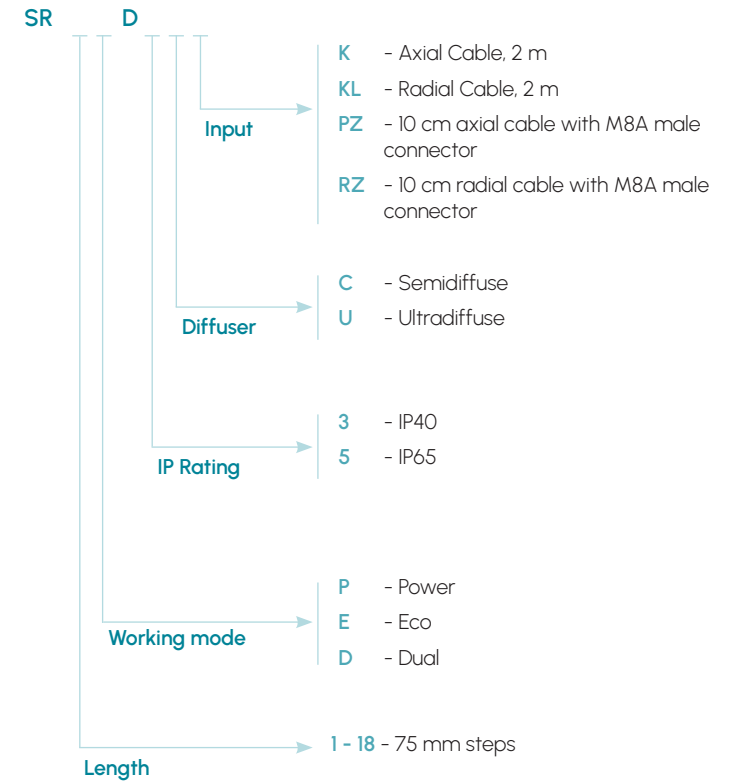

lumher

SR Series · Daylight white 5000K



SR

5000K
DAYLIGHT
WHITE

→  →
SEMIDIFFUSE
150°

→  →
ULTRADIFFUSE
150°

PHOTOBIOLOGICAL
RISK
RG1 - LOW

60.000h
LIFESPAN

Table of characteristics

	Length L1 ⁽¹⁾ (mm)	Length L2 ⁽¹⁾ (mm)	Weight (g)	Illuminance Ev (lx) @ 1m				Luminous flux ⁽²⁾ (lm)		Power consumed (W)	
				SEMIDIFFUSE		ULTRADIFFUSE		POWER	ECO	POWER	ECO
	POWER	ECO	POWER	ECO	POWER	ECO					
	SR 01...	105	123	89	56	28	34	17	251	126	1,6
SR 02...	180	198	129	111	56	67	33	502	251	3,2	1,6
SR 03...	255	273	169	167	84	101	50	754	377	4,8	2,4
SR 04...	330	348	209	222	112	134	67	1.005	502	6,4	3,2
SR 05...	405	423	249	278	140	168	83	1.256	628	8,0	4,0
SR 06...	480	498	289	333	168	201	100	1.507	754	9,6	4,8
SR 07...	555	573	329	389	196	235	117	1.758	879	11,2	5,6
SR 08...	630	648	369	444	224	268	133	2.010	1.005	12,8	6,4
SR 09...	705	723	409	500	251	302	150	2.261	1.130	14,4	7,2
SR 10...	780	798	449	556	279	335	167	2.512	1.256	16,0	8,0
SR 11...	855	873	489	611	307	369	183	2.763	1.382	17,6	8,8
SR 12...	930	948	529	667	335	402	200	3.014	1.507	19,2	9,6
SR 13...	1.005	1.023	569	722	363	436	217	3.266	1.633	20,8	10,4
SR 14...	1.080	1.098	609	778	391	469	233	3.517	1.758	22,4	11,2
SR 15...	1.155	1.173	649	833	419	503	250	3.768	1.884	24,0	12,0
SR 16...	1.230	1.248	689	889	447	536	267	4.019	2.010	25,6	12,8
SR 17...	1.305	1.323	729	944	475	570	283	4.270	2.135	27,2	13,6
SR 18...	1.380	1.398	769	1.000	503	604	300	4.522	2.261	28,8	14,4

(1) Versions with radial input and/or radial output will have as length L2, the rest will be L1.
 (2) The luminous flux (lm) is before diffuser.